

Photoelectrics Amplifier Type S142B..

CARLO GAVAZZI



- μ -Processor controlled
- Amplifier relay for photoelectric switches
- Automatic or manual emitter power regulation
- Self-diagnostic functions
- Alignment help
- Rated operational voltage:
24 VAC/DC, 115 VAC or 230 VAC
- Output 8 A/250 VAC SPDT relay and 100 mA NPN
- LED indication: Automatic gain, output, level, emitter or receiver fault



Product Description

μ -Processor controlled amplifier for one set of photoelectric sensors, type MOFTR. Utilising an 11-pin circular plug for easy connection. 8 A SPDT relay output, NPN / PNP transistor output or alarm output. Diagnostics for sensor test during opera-

tion. Alignment help via LED or alternation of alarm output. Level indication for dirt accumulation. Manual or automatic emitter power regulation. Two emitter codes available for high neighbour immunity. ON- or OFF delay adjustable up to 10 sec.

Ordering Key

S142 B RNN 924

Type _____
 Special function _____
 Output type _____
 (R-Relay, N-NPN, P-PNP, T-Test)
 Power supply _____

Type Selection

Function diameter	Delay	Ordering no. Supply: 24 VAC/DC	Ordering no. Supply: 115 VAC	Ordering no. Supply: 230 VAC
NPN output & Test input	ON & OFF	S142 B RNT 924	S142 B RNT 115	S142 B RNT 230
NPN output & Alarm output	ON & OFF	S142 B RNN 924¹⁾	S142 B RNN 115¹⁾	S142 B RNN 230¹⁾
PNP out., PNP Alarm & Test	ON & OFF	S142 B PPT 924	S142 B PPT 115	S142 B PPT 230

¹⁾ Amplifier replacement for S1421156xxx

Specifications

Rated operational voltage (U_B) Pins 2 & 10	230 115 924	195 to 265 VAC, 45 to 65 Hz 98 to 132 VAC, 45 to 65 Hz 20.4 to 27.6 VAC/DC Class 2	Test input (Mute) Emitter Enabled Emitter Disabled Imax @ 40 VDC	NPN > 5.0 VDC < 3.0 VDC 1 mA	PNP < $V_{CC} - 3$ VDC > $V_{CC} - 5$ VDC
Rated operational power AC supply AC/DC supply	3.3 VA 1.6 VA / 1.4 W		Protection output transistor	Reverse polarity, short circuit and transients	
Delay on operate (t_v)	< 300 mS		Supply to sensors Emitter Supply voltage (open loop) Current	Pins 5 & 7 15 V square wave < 450 mA, short circuit protected 10 Ω	
Outputs Relay Rating (AgCdO) Resistive loads AC1 DC1 or Electrical life (typical) AC1	μ (micro gap) 8 A / 250 VAC (2500 VA) 0.2 A / 250 VDC (50 W) 2 A 25 VDC (50 W) > 100.000 operations		Receiver Supply voltage (open loop) Short-circuit current Input resistance	Pins 6 & 8 5 VDC 10 mA 470 Ω	
Transistor output data Output current (I_e)	< 100 mA @ 40 VDC (max. load capacity 100 nF)				
Voltage drop (U_d)	< 2,5 VDC @ 100 mA				
Output function Relay Transistor Alarm	Make or break on DIP-switch SPDT NPN / PNP, 100 mA, 40 VDC NPN / PNP, 100 mA, 40 VDC Delay on alarm 10 sec				

Specifications

Emitter power Power	Settings on DIP switch no 4, 50 % or 100 % range	Transistor output	5 Hz min delay
Adjustment Manual Automatic (Auto LED ON)	240° Potentiometer Potentiometer settings to minimum	Response time OFF-ON (t_{ON}) ON-OFF (t_{OFF})	0.1 – 10 s 0.1 – 10 s
Sensing distance	Maximum range indicated on photoelectric switch data- sheets in 100 % settings	Environment Overvoltage category Degree of protection Pollution degree	III (IEC 60664) IP 20 /IEC 60529, 60947-1) 3 (IEC 60664/60664A, 60947-1)
Rated insulation voltage (U_i)	250 VAC	Temperature Operating Storage	-20° to +50°C (-4° to +122°F) -50° to +85°C (-58° to +185°F)
Dielectric voltage	>2.0 KVAC (rms) (contacts / electronics)	Housing material	NORYL SE1, light grey
Rated impulse withstand volt.	4 kV (1.2/50 μ S) (contacts / electronics) (IEC 664)	Weight AC supply AC/DC supply	200 g 125 g
Operating frequency (f) Light / Dark ratio 1:1 Relay output	5 Hz min delay	Approvals CE marking	UL508, UL325, CSA EN12445, EN12453, EN12978

Specifications

Diagnostic

If a fault occurs on either the emitter or receiver the Alarm LED and output will turn ON.

Receiver fault:

During normal operation the receiver is monitored for faults.

If the wires are short-circuited the "Code A, Green LED" flashes at a rate of 2 Hz.

If the wires are broken the "Code A, Green LED" flashes at a rate of 4 Hz.

Emitter fault:

During normal operation the emitter is monitored for faults.

If the wires are short-circuited the "Code B, Yellow LED" flashes at a rate of 2 Hz.
If the wires are broken the "Code B, Yellow LED" flashes at a rate of 4 Hz.

Alignment:

If the alignment DIP switch is set the Yellow Signal LED Flashes according to the signal quality.

Low frequency means weak signal.

Steady indication means maximum signal. On long distance it is not possible to get a steady signal but the alignment is optimal when the led flashes with the highest frequency.

On short distance the emitter power can be reduced using the potentiometer and then get better readings in the alignment LED.

The ALARM output will follow the Signal LED in align-

ment mode, so a Sensor tester (optional) can be connected to serve as a remote induction during alignment of the sensors.

NB! In alignment mode the output is off.

Code A or B

When two sensor pairs are mounted close to each other it is recommended to select one set to Code A and the other to Code B to avoid crosstalk.

Operation Diagram

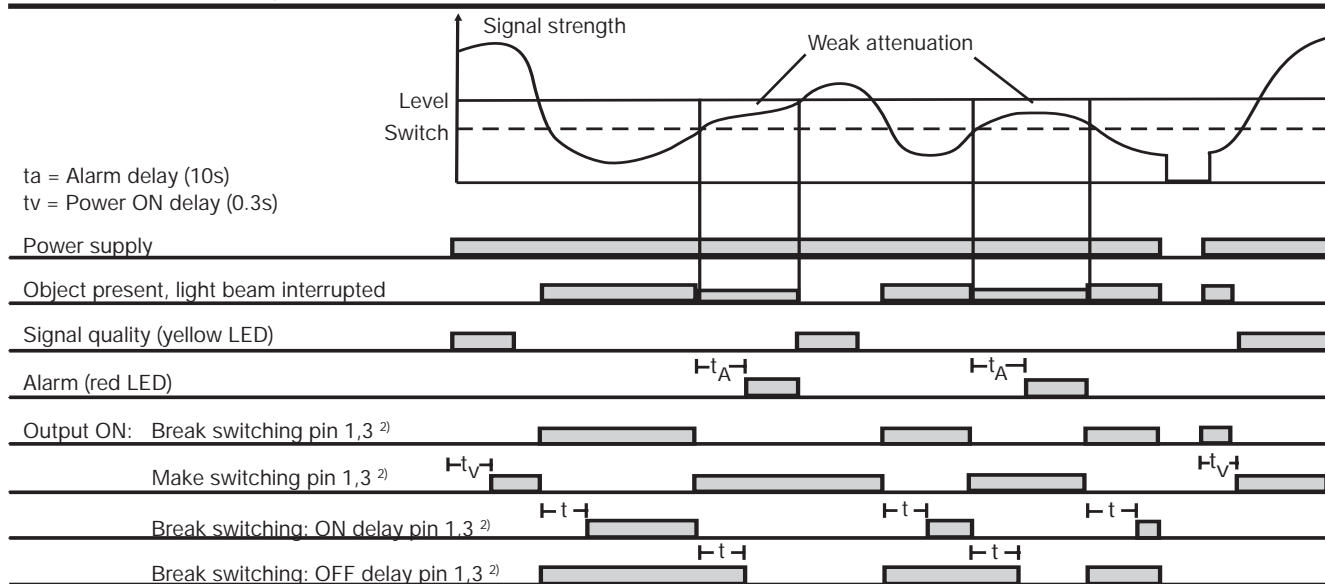

²⁾ Switching function selected by DIP-switch, inverted function on pin 1, 4

Dimensions

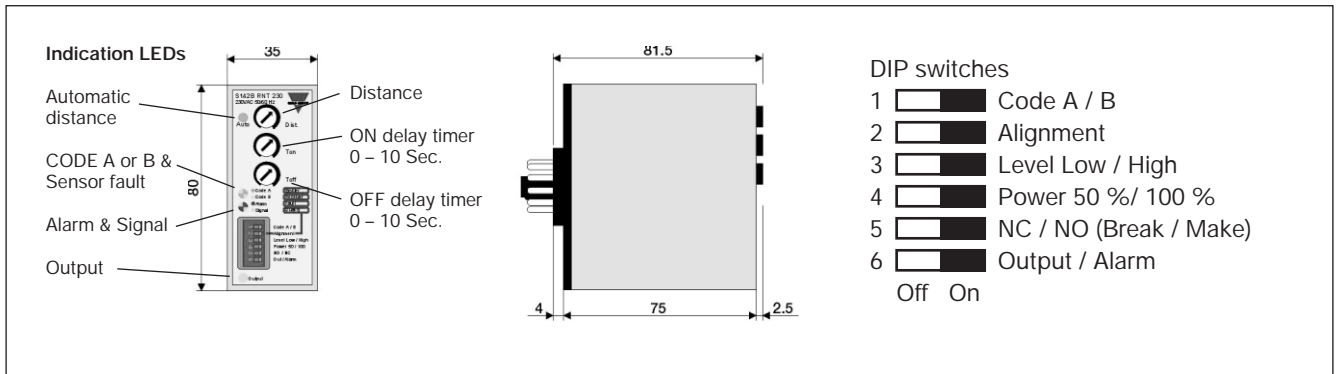

Wiring Diagram

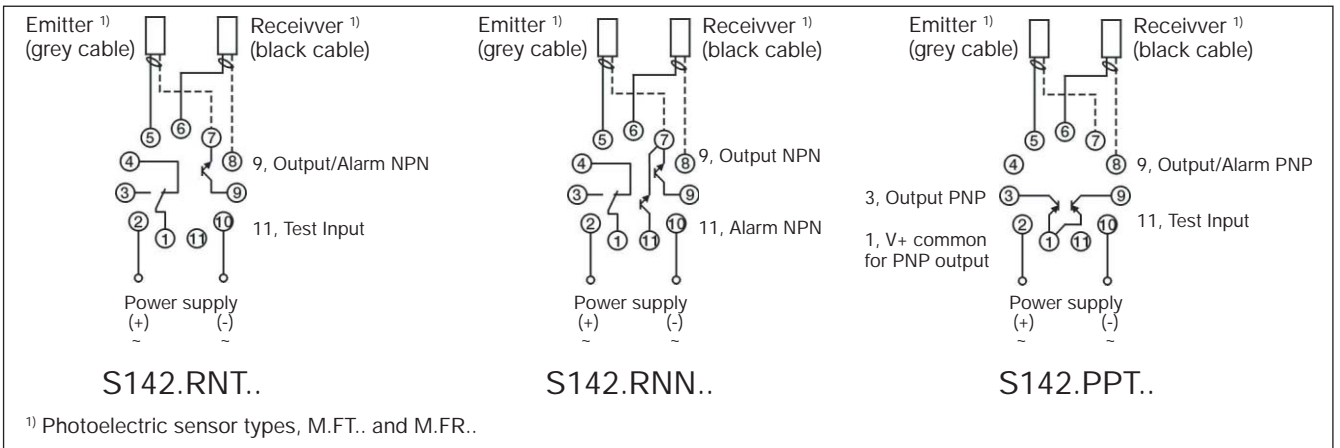

Connection to sortester

Connection to sortester ST-03 for alignment

	Sortester		
	-	Signal	+
RNT Pin no.	10	9	
RNN Pin no.	10	11	
PPT Pin no.		9	2

Accessories

- 11 pole circular socket ZPD11
- Holding down spring HF
- Mounting rack SM13
- Front panel mounting bezel FRS2

Delivery Contents

- Amplifier
- **Packaging:** Carton box