

PRELIMINARY DATA SHEET

NEC

C BAND SUPER LOW NOISE HJ FET

NE334S01

FEATURES

- **VERY LOW NOISE FIGURE:**
0.25 dB TYP at 4 GHz
- **HIGH ASSOCIATED GAIN:**
16.0 dB TYP at 4 GHz
- **GATE WIDTH:** 280 μm
- **TAPE & REEL PACKAGING OPTION AVAILABLE**
- **LOW COST PLASTIC PACKAGE**

DESCRIPTION

The NE334S01 is a Hetero-Junction FET that uses the junction between Si-doped AlGaAs and undoped InGaAs to create very high mobility electrons. Its excellent low noise and high associated gain make it suitable for TVRO and other commercial systems.

NEC's stringent quality assurance and test procedures assure the highest reliability and performance.

**MAXIMUM AVAILABLE GAIN, FORWARD
INSERTION GAIN vs. FREQUENCY**

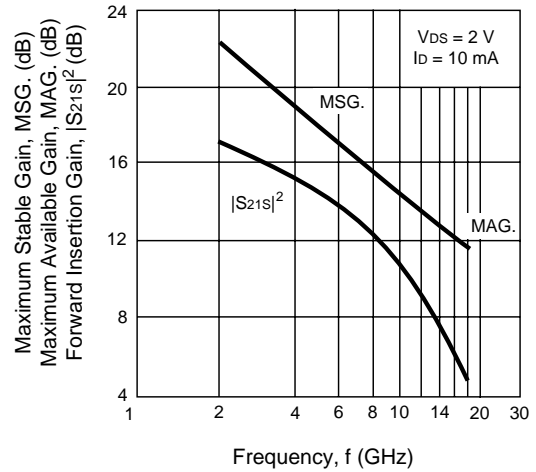

RECOMMENDED OPERATING CONDITION (TA = 25°C)

SYMBOLS	CHARACTERISTIC	UNITS	MIN	TYP	MAX
V _{DS}	Drain to Source Voltage	V		2	2.5
I _D	Drain Current	mA		15	20
P _{IN}	Input Power	dBm			0

ELECTRICAL CHARACTERISTICS (TA = 25°C)

PART NUMBER PACKAGE OUTLINE			NE334S01 S01		
SYMBOLS	PARAMETERS AND CONDITIONS	UNITS	MIN	TYP	MAX
NF ¹	Noise Figure, V _{DS} = 2.0 V, I _D = 15 mA, f = 4 GHz	dB		0.25	0.35
GA ¹	Associated Gain, V _{DS} = 2.0 V, I _D = 15 mA, f = 4 GHz	dB	15.0	16.0	
I _{DSS}	Saturated Drain Current, V _{DS} = 2.0 V, V _{GS} = 0 V	mA	20	80	150
g _m	Transconductance, V _{DS} = 2.0 V, I _D = 14 mA	mS	70	85	
V _{GS(off)}	Gate to Source Cutoff Voltage, V _{DS} = 2.0 V, I _D = 100 μA ,	V	-0.2	-0.9	-2.5
I _{GSO}	Gate to Source Leak Current, V _{GS} = -3.0 V	μA		0.5	10

Note:

1. Typical values of noise figures and associated gain are those obtained when 50% of the devices from a large number of lots were individually measured in a circuit with the input individually tuned to obtain the minimum value. Maximum values are criteria established on the production line as a "go-no-go" screening tuned for the "generic" type but not each specimen.

ABSOLUTE MAXIMUM RATINGS¹ (T_A = 25°C)

SYMBOLS	PARAMETERS	UNITS	RATINGS
V _{DS}	Drain to Source Voltage	V	4.0
V _{GS}	Gate to Source Voltage	V	-3.0
I _{DS}	Drain Current	mA	I _{DSS}
T _{CH}	Channel Temperature	°C	125
T _{STG}	Storage Temperature	°C	-65 to +125
P _T	Total Power Dissipation	mW	300

Note:

1. Operation in excess of any one of these conditions may result in permanent damage.

TYPICAL NOISE PARAMETERS (T_A = 25°C)

V_{DS} = 2 V, I_{DS} = 15 mA

FREQ. (GHz)	NF _{MIN} (dB)	G _A (dB)	Γ _{OPT}		R _n /50
			MAG	ANG	
2	0.23	17.0	0.77	15	0.19
4	0.25	16.0	0.58	43	0.18
6	0.28	14.7	0.43	82	0.13
8	0.31	13.6	0.32	127	0.08
10	0.38	12.5	0.27	175	0.07
12	0.48	11.5	0.27	-139	0.10
14	0.60	10.5	0.34	-100	0.17
16	0.73	9.6	0.48	-70	0.29
18	0.88	8.8	0.69	-56	0.46

TYPICAL PERFORMANCE CURVES (T_A = 25°C)

TOTAL POWER DISSIPATION vs. AMBIENT TEMPERATURE

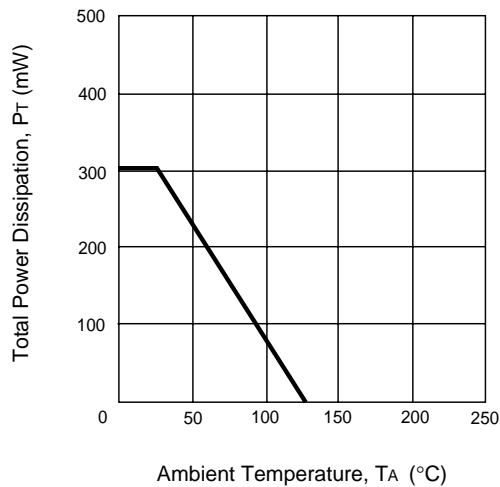

TYPICAL CONSTANT NOISE FIGURE CIRCLE (V_{DS} = 2 V, I_{DS} = 15 mA, f = 4 GHz)

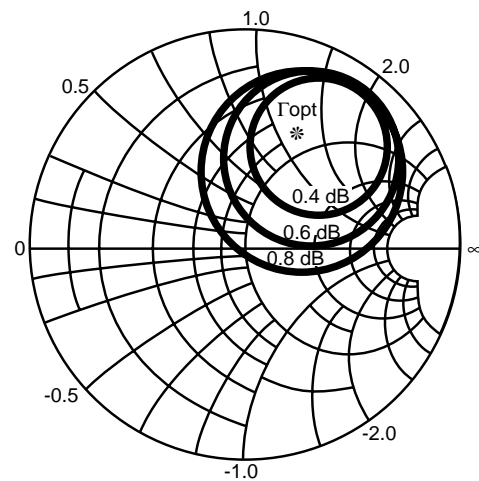

DRAIN CURRENT vs. GATE TO SOURCE VOLTAGE

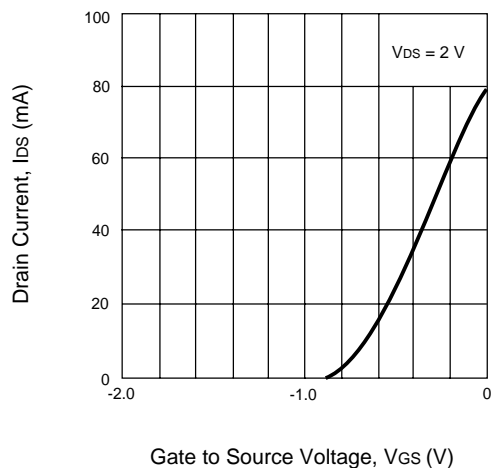

DRAIN CURRENT vs. DRAIN TO SOURCE VOLTAGE

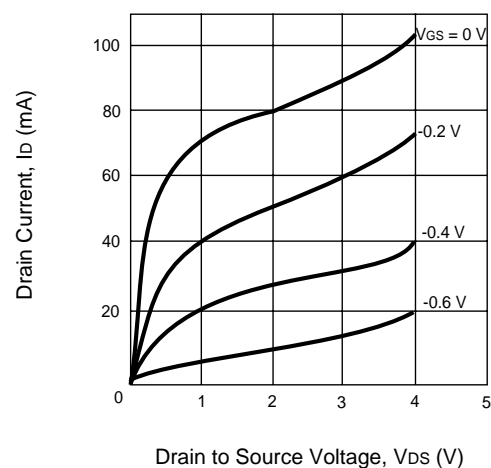

TYPICAL COMMON SOURCE SCATTERING PARAMETERS (T_A = 25°C)

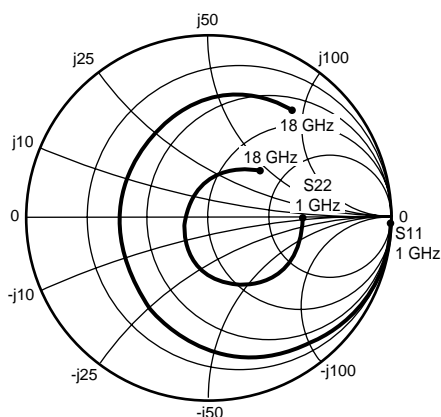

Coordinates in Ohms
Frequency in GHz
V_{DS} = 2 V, I_D = 10 mA

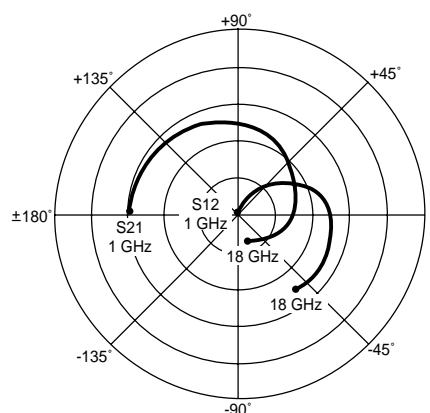

V_{DS} = 2 V, I_D = 10 mA

FREQUENCY (GHz)	S ₁₁		S ₂₁		S ₁₂		S ₂₂		K	MAG ¹ (dB)
	MAG	ANG	MAG	ANG	MAG	ANG	MAG	ANG		
0.1	1.002	-2.0	5.985	177.7	0.002	96.6	0.538	-1.3	-0.17	34.5
0.5	0.996	-9.7	5.938	170.3	0.013	84.0	0.535	-7.5	0.06	26.7
1.0	0.981	-19.2	5.855	160.9	0.025	77.2	0.529	-15.1	0.14	23.7
1.5	0.960	-28.6	5.765	151.7	0.036	71.1	0.518	-22.4	0.21	22.0
2.0	0.933	-38.0	5.671	142.7	0.048	65.5	0.504	-29.9	0.26	20.8
2.5	0.903	-47.4	5.554	133.9	0.058	59.6	0.488	-37.0	0.32	19.8
3.0	0.869	-57.0	5.429	125.1	0.068	53.6	0.467	-44.3	0.37	19.0
3.5	0.829	-66.6	5.279	116.5	0.078	48.3	0.445	-51.5	0.43	18.3
4.0	0.788	-76.5	5.126	108.0	0.086	42.5	0.420	-58.3	0.49	17.7
4.5	0.746	-86.5	4.954	99.4	0.094	37.3	0.394	-65.9	0.54	17.2
5.0	0.702	-96.7	4.773	91.2	0.100	32.3	0.366	-73.2	0.60	16.8
5.5	0.662	-107.1	4.593	83.2	0.106	27.5	0.339	-81.0	0.65	16.4
6.0	0.625	-117.7	4.421	75.5	0.111	22.5	0.309	-88.6	0.70	16.0
6.5	0.594	-128.4	4.232	67.9	0.115	17.5	0.282	-96.4	0.75	15.7
7.0	0.566	-139.1	4.059	60.5	0.119	13.2	0.257	-104.5	0.79	15.3
7.5	0.545	-149.9	3.886	53.2	0.121	9.2	0.234	-112.8	0.84	15.1
8.0	0.528	-160.6	3.720	46.2	0.123	4.7	0.210	-121.7	0.88	14.8
8.5	0.514	-170.7	3.567	39.3	0.126	1.2	0.190	-129.4	0.92	14.5
9.0	0.511	179.1	3.426	32.5	0.128	-2.7	0.172	-139.7	0.95	14.3
9.5	0.510	168.8	3.292	25.8	0.129	-6.7	0.154	-150.9	0.98	14.1
10.0	0.514	158.8	3.151	19.0	0.131	-10.8	0.142	-164.7	1.01	13.2
10.5	0.521	148.9	3.021	12.5	0.132	-14.2	0.132	177.8	1.04	12.4
11.0	0.532	139.2	2.894	6.3	0.131	-17.9	0.122	158.9	1.08	11.7
11.5	0.543	131.0	2.764	0.2	0.132	-21.8	0.125	143.5	1.11	11.2
12.0	0.562	123.0	2.654	-6.0	0.132	-25.0	0.138	128.5	1.12	10.9
12.5	0.580	115.5	2.544	-12.2	0.131	-28.8	0.153	115.5	1.14	10.6
13.0	0.598	108.5	2.437	-18.1	0.131	-32.0	0.172	104.0	1.15	10.3
13.5	0.618	102.0	2.338	-24.2	0.130	-35.5	0.189	95.6	1.16	10.1
14.0	0.627	95.8	2.251	-30.3	0.129	-39.0	0.203	87.7	1.18	9.8
14.5	0.642	90.1	2.161	-36.3	0.129	-42.3	0.223	82.4	1.18	9.6
15.0	0.657	84.4	2.074	-42.3	0.130	-46.2	0.243	75.6	1.19	9.4
15.5	0.671	78.8	1.987	-48.6	0.127	-50.0	0.262	69.7	1.21	9.2
16.0	0.687	73.6	1.902	-54.5	0.126	-54.0	0.284	63.5	1.21	9.0
16.5	0.704	68.2	1.821	-60.3	0.126	-57.5	0.306	57.0	1.21	8.8
17.0	0.718	63.2	1.736	-66.0	0.123	-61.2	0.328	52.2	1.23	8.6
17.5	0.731	58.7	1.649	-71.7	0.121	-64.3	0.347	47.6	1.25	8.4
18.0	0.749	53.9	1.580	-77.1	0.120	-68.0	0.371	42.6	1.23	8.3

Note:

1. Gain Calculations:

$$MAG = \frac{|S_{21}|}{|S_{12}|} (K \pm \sqrt{K^2 - 1})$$

When K ≤ 1, MAG is undefined and MSG values are used. $MSG = \frac{|S_{21}|}{|S_{12}|}$, $K = \frac{1 + |\Delta|^2 - |S_{11}|^2 - |S_{22}|^2}{2 |S_{12} S_{21}|}$, $\Delta = S_{11} S_{22} - S_{21} S_{12}$

MAG = Maximum Available Gain

MSG = Maximum Stable Gain

TYPICAL COMMON SOURCE SCATTERING PARAMETERS (TA = 25°C)

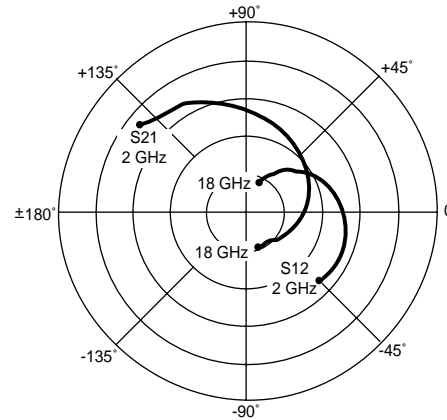
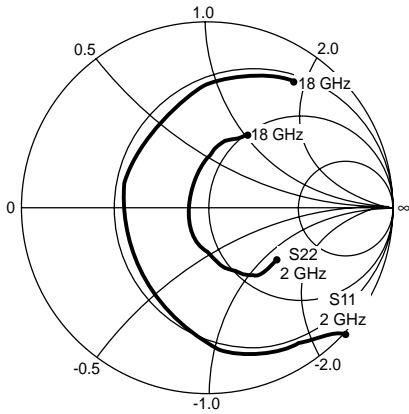

Coordinates in Ohms
Frequency in GHz
Vds = 2 V, Id = 15 mA

Vds = 2 V, Id = 15 mA

FREQUENCY (GHz)	S11		S21		S12		S22		K	MAG ¹ (dB)
	MAG	ANG	MAG	ANG	MAG	ANG	MAG	ANG		
2.0	.998	-41.7	7.162	140.1	.042	68.4	.415	-27.5	.10	41.82
2.5	.927	-47.5	6.856	133.6	.050	65.9	.479	-35.8	.23	26.36
3.0	.860	-61.3	6.603	122.0	.057	57.5	.423	-43.0	.39	23.09
3.5	.829	-69.9	6.305	114.4	.064	54.1	.429	-47.9	.42	21.91
4.0	.802	-79.2	6.033	106.8	.071	49.6	.426	-51.7	.45	20.95
4.5	.716	-87.5	5.687	98.5	.075	45.8	.406	-56.2	.60	19.00
5.0	.659	-93.9	5.415	91.6	.081	41.1	.394	-59.7	.69	17.88
5.5	.601	-99.7	5.184	84.7	.085	38.9	.374	-63.3	.78	16.89
6.0	.592	-108.5	5.050	77.6	.091	35.2	.340	-68.1	.79	16.47
6.5	.550	-118.5	4.912	70.5	.096	30.8	.311	-73.0	.84	15.83
7.0	.514	-130.2	4.774	63.0	.102	27.3	.279	-79.1	.87	15.26
7.5	.488	-144.5	4.600	55.4	.107	22.0	.232	-87.5	.91	14.68
8.0	.464	-158.9	4.401	47.9	.109	18.6	.189	-97.7	.96	14.08
8.5	.463	-171.7	4.187	41.0	.113	14.9	.155	-109.3	.98	13.59
9.0	.468	176.6	3.997	34.1	.114	11.5	.134	-126.9	1.00	15.01
9.5	.472	166.4	3.812	27.7	.118	7.7	.121	-142.8	1.02	14.21
10.0	.472	156.2	3.628	21.5	.119	4.7	.111	-156.2	1.06	13.37
10.5	.476	147.0	3.477	15.6	.122	1.0	.103	-170.1	1.08	12.86
11.0	.476	137.8	3.351	9.6	.124	-2.5	.098	174.4	1.10	12.36
11.5	.488	127.7	3.251	3.5	.125	-5.8	.093	157.9	1.12	12.06
12.0	.518	118.1	3.150	-2.9	.128	-9.2	.105	137.6	1.10	11.98
12.5	.552	109.6	3.036	-9.7	.130	-12.9	.131	121.0	1.08	11.92
13.0	.593	101.9	2.875	-16.4	.131	-16.7	.177	107.0	1.07	11.79
13.5	.635	95.2	2.714	-22.7	.129	-21.2	.223	97.8	1.06	11.70
14.0	.661	90.1	2.546	-28.1	.126	-22.5	.259	91.0	1.08	11.29
14.5	.688	86.1	2.418	-32.6	.124	-24.9	.284	87.0	1.08	11.17
15.0	.707	82.2	2.327	-37.0	.127	-27.4	.316	86.0	1.05	11.30
15.5	.719	79.7	2.240	-41.8	.126	-28.8	.332	83.3	1.04	11.20
16.0	.730	76.1	2.168	-46.8	.129	-31.6	.352	81.7	1.01	11.55
16.5	.752	71.3	2.100	-52.7	.131	-33.2	.380	77.4	.98	10.74
17.0	.771	65.5	2.021	-58.4	.130	-38.5	.398	72.4	.96	10.78
17.5	.803	60.4	1.930	-65.1	.134	-42.2	.422	66.5	.89	11.05
18.0	.817	55.7	1.814	-70.5	.128	-44.3	.445	62.9	.91	10.92

Note:

1. Gain Calculations:

$$MAG = \frac{|S_{21}|}{|S_{12}|} (K \pm \sqrt{K^2 - 1}). \text{ When } K \leq 1, \text{ MAG is undefined and MSG values are used. } MSG = \frac{|S_{21}|}{|S_{12}|}, K = \frac{1 + |\Delta|^2 - |S_{11}|^2 - |S_{22}|^2}{2 |S_{12} S_{21}|}, \Delta = S_{11} S_{22} - S_{21} S_{12}$$

MAG = Maximum Available Gain

MSG = Maximum Stable Gain

TYPICAL COMMON SOURCE SCATTERING PARAMETERS (TA = 25°C)

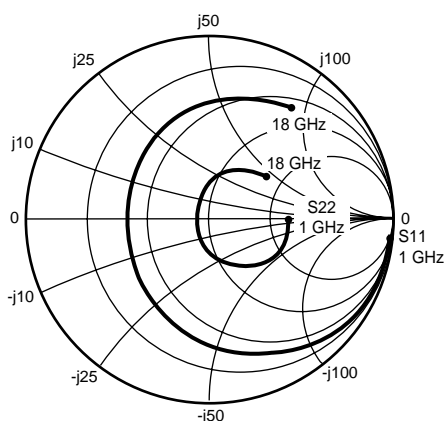

Coordinates in Ohms
Frequency in GHz
Vds = 2 V, Id = 20 mA

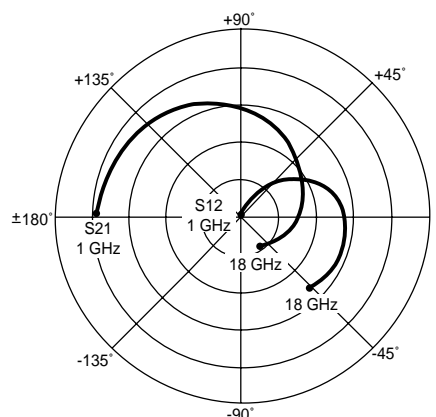

Vds = 2 V, Id = 20 mA

FREQUENCY (GHz)	S11		S21		S12		S22		K	MAG ¹ (dB)
	MAG	ANG	MAG	ANG	MAG	ANG	MAG	ANG		
0.1	1.002	-2.2	7.768	177.7	0.003	83.5	0.439	-1.4	-0.01	33.9
0.5	0.994	-10.7	7.685	169.3	0.011	85.2	0.436	-7.7	0.08	28.4
1.0	0.974	-21.3	7.530	159.0	0.022	77.5	0.430	-15.5	0.18	25.3
1.5	0.946	-31.7	7.350	149.1	0.033	71.7	0.419	-23.1	0.26	23.5
2.0	0.911	-41.9	7.155	139.5	0.042	66.3	0.405	-30.5	0.33	22.3
2.5	0.870	-52.0	6.927	130.1	0.051	61.3	0.388	-37.8	0.40	21.3
3.0	0.826	-62.2	6.682	121.0	0.060	55.8	0.367	-45.0	0.47	20.5
3.5	0.780	-72.4	6.418	112.1	0.068	50.5	0.346	-52.1	0.53	19.7
4.0	0.733	-82.6	6.152	103.5	0.076	45.6	0.322	-58.7	0.60	19.1
4.5	0.685	-93.1	5.871	95.0	0.083	40.9	0.298	-66.3	0.65	18.5
5.0	0.640	-103.6	5.592	86.9	0.088	36.3	0.272	-73.5	0.71	18.0
5.5	0.599	-114.3	5.326	79.1	0.094	31.9	0.248	-81.3	0.76	17.6
6.0	0.565	-125.1	5.077	71.6	0.099	27.7	0.222	-89.0	0.81	17.1
6.5	0.536	-136.0	4.822	64.3	0.103	23.8	0.198	-97.3	0.85	16.7
7.0	0.512	-146.9	4.595	57.2	0.107	19.5	0.176	-106.2	0.90	16.3
7.5	0.496	-157.8	4.375	50.2	0.111	16.0	0.156	-115.6	0.93	16.0
8.0	0.483	-168.6	4.166	43.5	0.113	11.8	0.138	-126.3	0.97	15.7
8.5	0.473	-178.5	3.979	37.0	0.117	8.6	0.120	-135.8	1.00	15.3
9.0	0.475	171.5	3.807	30.4	0.120	5.0	0.107	-149.5	1.02	14.2
9.5	0.478	161.6	3.644	24.0	0.123	1.2	0.096	-165.3	1.04	13.5
10.0	0.487	152.0	3.479	17.6	0.125	-2.9	0.092	175.2	1.06	13.0
10.5	0.498	142.5	3.327	11.4	0.128	-6.2	0.097	152.5	1.07	12.5
11.0	0.514	133.3	3.181	5.4	0.128	-9.7	0.103	130.1	1.10	12.0
11.5	0.527	125.6	3.036	-0.4	0.130	-13.7	0.116	116.5	1.11	11.6
12.0	0.548	118.1	2.911	-6.4	0.131	-17.1	0.137	104.9	1.12	11.4
12.5	0.569	111.1	2.789	-12.3	0.132	-21.0	0.160	95.2	1.13	11.1
13.0	0.589	104.4	2.670	-18.0	0.132	-24.2	0.184	86.9	1.13	10.8
13.5	0.610	98.4	2.562	-23.8	0.132	-28.0	0.203	80.3	1.14	10.6
14.0	0.620	92.4	2.466	-29.7	0.134	-31.7	0.218	73.7	1.15	10.3
14.5	0.636	86.9	2.368	-35.5	0.134	-35.6	0.237	69.5	1.15	10.2
15.0	0.652	81.5	2.272	-41.4	0.134	-39.6	0.259	64.1	1.15	10.0
15.5	0.668	76.1	2.178	-47.5	0.134	-43.7	0.277	58.7	1.15	9.8
16.0	0.684	71.2	2.082	-53.2	0.133	-48.0	0.300	53.8	1.16	9.6
16.5	0.702	66.1	1.994	-58.8	0.132	-51.5	0.324	48.2	1.15	9.4
17.0	0.716	61.1	1.904	-64.3	0.130	-55.5	0.344	44.0	1.16	9.2
17.5	0.731	56.8	1.810	-69.8	0.128	-59.1	0.362	39.7	1.17	9.0
18.0	0.750	52.0	1.737	-75.0	0.127	-62.6	0.385	35.1	1.16	8.9

Note:

1. Gain Calculations:

$$MAG = \frac{|S_{21}|}{|S_{12}|} (K \pm \sqrt{K^2 - 1})$$

When K ≤ 1, MAG is undefined and MSG values are used. $MSG = \frac{|S_{21}|}{|S_{12}|}$, $K = \frac{1 + |\Delta|^2 - |S_{11}|^2 - |S_{22}|^2}{2 |S_{12} S_{21}|}$, $\Delta = S_{11} S_{22} - S_{21} S_{12}$

MAG = Maximum Available Gain

MSG = Maximum Stable Gain

OUTLINE DIMENSIONS (Units in mm)

PACKAGE OUTLINE S01

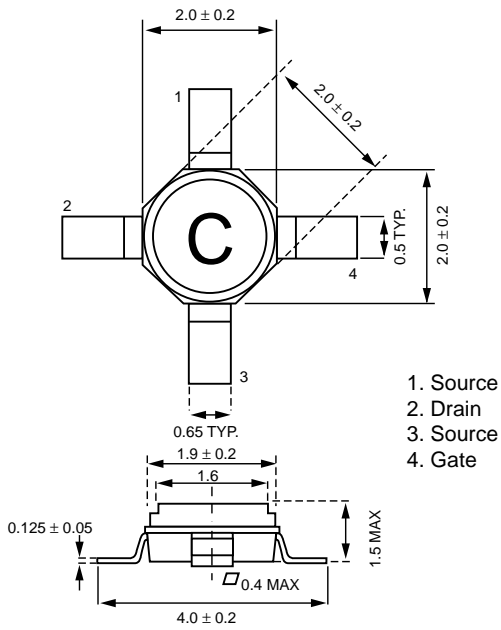

- 1. Source
- 2. Drain
- 3. Source
- 4. Gate

ORDERING INFORMATION

PART NUMBER	AVAILABILITY	PACKAGE
NE334S01	Bulk	S01
NE334S01-T1	Tape & reel 1K/reel	S01
NE334S01-T1B	Tape & reel 4K/reel	S01

EXCLUSIVE NORTH AMERICAN AGENT FOR **NEC** RF, MICROWAVE & OPTOELECTRONIC SEMICONDUCTORS

CEL CALIFORNIA EASTERN LABORATORIES • Headquarters • 4590 Patrick Henry Drive • Santa Clara, CA 95054-1817 • (408) 988-3500 • Telex 34-6393 • FAX (408) 988-0279
 24-Hour Fax-On-Demand: 800-390-3232 (U.S. and Canada only) • Internet: <http://WWW.CEL.COM>

DATA SUBJECT TO CHANGE WITHOUT NOTICE

7/18/2000

Mouser Electronics

Authorized Distributor

Click to View Pricing, Inventory, Delivery & Lifecycle Information:

[NEC:](#)

[NE325S01](#) [NE32584C-S](#) [NE325S01-T1B](#)