



FEATURES

- Wide input voltage range 85 - 264VAC or 120 - 370VDC
- Accepts AC or DC input (dual-use of same terminal)
- Built-in active PFC function
- Operating ambient temperature range: -40°C to +70°C
- High reliability, efficiency up to 94%
- Output short circuit, 5s constant-current, over-voltage, over-temperature protection
- Support 3+1 parallel redundancy, current sharing
- Operating up to 5000m altitude
- Fan speed automatic adjustable
- 5 years warranty
- Comply with IEC/UL62368, IEC60601, IEC60335, GB4943



BS EN62368-1

EN62368-1
EN60601-1

ES60601-1

LMF1500-20Bxx series is one of Mornsun's enclosed AC-DC switching power supply. It features universal AC input and at the same time accepts DC input voltage, cost-effective, low no load power consumption, high efficiency, high reliability and double or reinforced insulation. These converters offer excellent EMC performance and meet IEC/EN/UL/BS EN62368, EN/ES/IEC60601, IEC60335, GB4943 standards and they are widely used in areas of industrial, LED, street light control, electricity, security, telecommunications, smart home. etc.

Selection Guide

Certification	Part No.*	Output Power (W)	Nominal Output Voltage and Current (Vo/Io)		Output Voltage Adjustable Range (V) Vo1	Efficiency at 230VAC (%) Typ.	Max. Capacitive Load (μF)	
			Vo1/Io1	Vo2/Io2			Vo1	Vo2
BS/EN/ES/BIS	LMF1500-20B12	1510	12V/125A		12-14.4	92	40000	1000
	LMF1500-20B15	1510	15V/100A		15-18	92	20000	
	LMF1500-20B24	1510	24V/62.5A		24-28.8	94	10000	
	LMF1500-20B27	1522	27V/56A		27-32.4	94	8000	
BS/EN/ES/BIS	LMF1500-20B36	1522	36V/42A		36-43.2	94	6000	
	LMF1500-20B48	1546	48V/32A		48-56	94	4000	
BS/EN/ES	LMF1500-20B54	1522	54V/28A		54-58	94	3000	

Note: 1.*Use suffix "QQ" for both sides conformal coating.

2.*Before powering on the product, please confirm whether the control signal connection terminal (CN7) Pin6 (PS_ON) and Pin7 (GND) short-circuit jumper cap are connected (Factory comes with short-circuit jumper cap). If not, the product without output. When the control signal connection terminal (CN7) of the product are external connected as a whole, please ensure that Pin6 and Pin7(or Pin14) are short-circuit connected. MORNSUN has PJA-047 jumper terminals for sale. Please refer to LMF1500-20Bxx(-QQ) Series Power Supply Application Notes: 2.10 Remote control.

3.*When using the current sharing function for all models, do not directly increase the load on the system beyond the rated load of a single prototype when the power is turned on for the first time.

Input Specifications

Item	Operating Conditions		Min.	Typ.	Max.	Unit
Input Voltage Range	Rated input		100	--	240	VAC
	AC input		85	--	264	
	DC input		120	--	370	VDC
Input Voltage Frequency			47	--	63	Hz
Input Current	115VAC		--	--	15.5	A
	230VAC		--	--	8	
Inrush Current	115VAC		--	3.7	20	
	230VAC		--	6.5	40	
Power Factor	115VAC		Room-temperature, full load			PF≥0.99
	230VAC					PF≥0.95
Leakage Current	240VAC		Earth leakage current		<0.5mA	
			Touch current		<0.1mA	
Hot Plug						Unavailable

Output Specifications

Item	Operating Conditions		Min.	Typ.	Max.	Unit
Output Voltage Accuracy	Full load range	Vo1	--	±1.0	--	%
		Vo2	--	±2.0	--	
Line Regulation	Rated load	Vo1	--	±0.5	--	
		Vo2	--	±1.0	--	
Load Regulation	0%-100% load	Vo1	--	±0.5	--	
		Vo2	--	±3.0	--	
Ripple & Noise*	20MHz bandwidth (peak-to-peak value)	Vo1:12V/15V/24V/27V	--	--	150	mV
		Vo1: 36V/48V	--	--	200	
		Vo1: 54V	--	--	250	
		Vo2: 5V	--	--	100	
Hold-up Time	Full input voltage		12	--	--	ms
Short Circuit Protection*	Recovery time <5s after the short circuit disappear		Hiccup, self-recover			
Constant Current Protection*	230VAC		Constant current limit, output voltage turn off after 5s, self-recover			
Over-voltage Protection	12V	≤16.5V	Output voltage turn off, re-power & PS_ON on for recover			
	15V	≤25.0V				
	24V	≤33.0V				
	27V	≤35.0V				
	36V	≤48.0V				
	48V	≤60.0V				
	54V	≤63.0V				
Over-temperature Protection	Over-temperature protection activation		--	--	70	°C
	Over-temperature protection deactivation		50	--	--	
Minimum Load			0	--	--	%
Dynamic Minimum Load			10	--	--	
Fan			The fan speed is linearly adjusted and determined by the output power and output voltage together			
Note:1. *The "Tip and barrel method" is used for ripple and noise test, output parallel 47uF electrolytic capacitor and 0.1uF ceramic capacitor, please refer to Enclosed Switching Power Supply Application Notes for specific information; 2.*Over current protection is realized in constant current mode, see section 2.6 of the application manual below; 3.*For auxiliary short-circuit mode, refer to section 2.7 of the application manual below.						

General Specifications.

Item	Operating Conditions		Min.	Typ.	Max.	Unit
Isolation Test	Input - output	Electric strength test for 1min., leakage current <10mA	4000	--	--	VAC
	Input - ⊕		2000	--	--	
	Output - ⊕		1500	--	--	
Insulation Resistance	Input - output	Environment temperature: 25±5°C Relative humidity: <95%RH, non-condensing Testing voltage: 500VDC	100	--	--	MΩ
	Input - ⊕			--	--	
	Output - ⊕			--	--	
Operating Temperature			-40	--	+70	°C
Storage Temperature			-40	--	+85	
Storage Humidity	Non-condensing		10	--	95	%RH
Operating Humidity			20	--	90	
Switching Frequency	PFC @ rated output		--	65	--	kHz
	LLC @ rated output		--	85	--	
Power Derating	Operating temperature	12V/15V	-40°C to -30°C	5	--	% / °C
			-30°C to +45°C	0	--	

	derating		+45°C to +70°C	1.6	--	--		
		24V/27V /36V/48V/ 54V		-40°C to -30°C	5	--		--
				-30°C to +50°C	0	--		--
				+50°C to +70°C	2	--		--
	Input voltage derating	85VAC - 100VAC		2	--	--	%/VAC	
	120VDC - 200VDC		0.875	--	--	%/VDC		
Safety Standard							ES60601-1 safety approved & BS EN/EN62368-1, EN60601-1 (Report) Design refer to IEC/UL62368-1, IEC60601-1, IEC60335-1, GB4943.1	
Safety Class							CLASS I	
Isolation Level	Input - output						2 x MOPP	
	Input - ⊕						1 x MOPP	
	Output - ⊕						1 x MOPP	
MTBF	MIL-HDBK-217F@25°C						>250,000 h	

Mechanical Specifications

Case Material	SUS 304
Dimensions	250.00mm x 127.00mm x 40.50mm
Weight	1800g (Typ.)
Cooling Method	25CFM
Note: *Cooling method and power derating refer to typical characteristic curves	

Electromagnetic Compatibility (EMC)

Emissions	CE	CISPR32/EN55032	150kHz—30MHz	CLASS B
	RE	CISPR32/EN55032	30MHz—1GHz	CLASS B
	Harmonic current	EN61000-3-2		CLASS A
Immunity	ESD	IEC/EN61000-4-2	Contact ±8KV/Air ±15KV	Perf. Criteria B
	RS	IEC/EN61000-4-3	80MHz - 1GHz 10V/m	Perf. Criteria A
	EFT	IEC/EN61000-4-4	±4KV, (5 or 100)kHz	Perf. Criteria B
	Surge*	IEC/EN61000-4-5	line to line ±2KV/line to PE ±4KV	Perf. Criteria B
	CS	IEC/EN61000-4-6	0.15MHz - 80MHz 10Vr.m.s	Perf. Criteria A
	Voltage dips, short interruptions and voltage variations	IEC/EN61000-4-11	70% U _n *, 25/30 periods (50/60Hz) 40% U _n *, 10/12 periods (50/60Hz) 0% U _n *, 1 periods	Perf. Criteria B

Note: 1. *It's able to meet the higher level of EMC if matching with Mornsun filter FC-L06WX series.
2. *U_n is the maximum input nominal voltage.

Functional Specifications

Item	Operating Conditions	Min.	Typ.	Max.	Unit	
Remote Control Switch	All input voltage range, all load range	Power on	PS_ON (CN7, Pin6) and GND (CN7, Pin7/14) are shorted			
		Power off	PS_ON (CN7 Pin6) and GND (CN7 Pin7/14) are open			
DC_OK Signal	All input voltage range, all load range	Power on	2.5	--	5	V
		Power off	--	--	0.5	
Oring		Support direct parallel use, achieve 3+1 parallel redundancy				
Current Sharing Accuracy	Output > 50%I _{o1}	--	±5	--	%	
LED Signal*	Main output status indication	Normal output	Green on			
		Abnormal output, protected	Red on			

		Power off (AC without input)	Light off			
Remote Sense	Total compensate voltage, Vs+/Vs- (CN7 Pin1/8) shorted to Vo+/Vo- respectively	--	200	--	mV	
SDA, SCL for I ² C		Internal 2.4kΩ pull-up resistor to internal 3.3V				
Note: *If the product is used in medical equipment, the terminal system should shield the LED signal light to meet the medical certification requirements that operators should not see the indicator light after the product is installed.						

Product Characteristic Curve

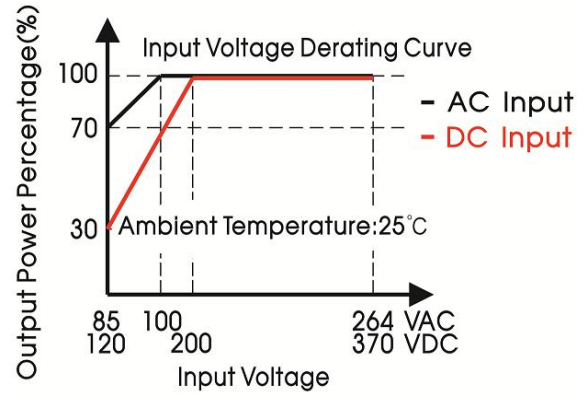
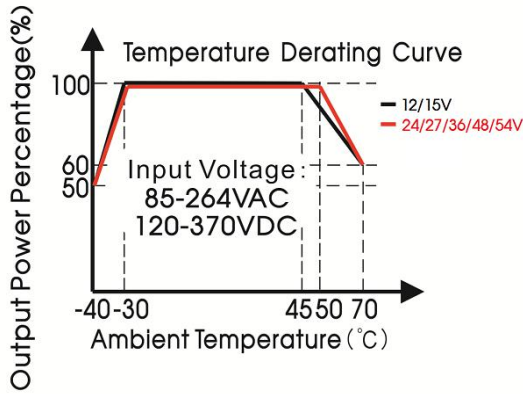

Note: 1. With an AC input voltage between 85 - 100VAC and a DC input between 120 - 200VDC the output power must be derated as per the temperature derating curves;

2. This product is suitable for use in natural air cooling environment. If used in closed environment, please consult our FAE.

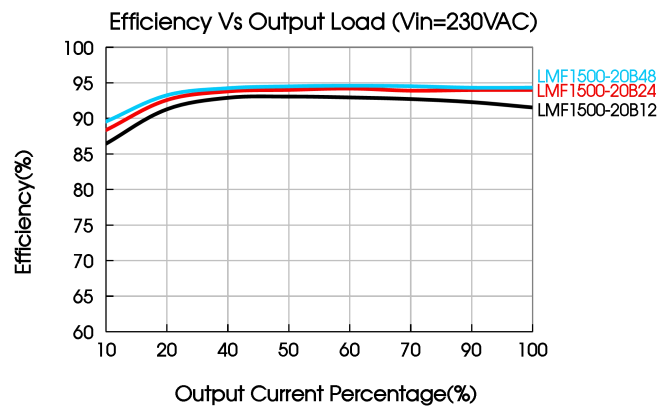
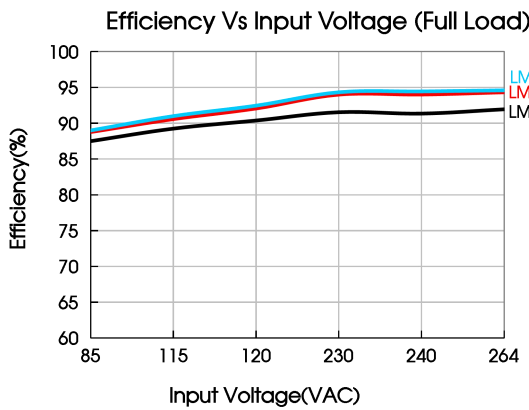

Dimensions and Recommended Layout

LMF1500-20Bxx, LMF1500-20Bxx-QQ Series

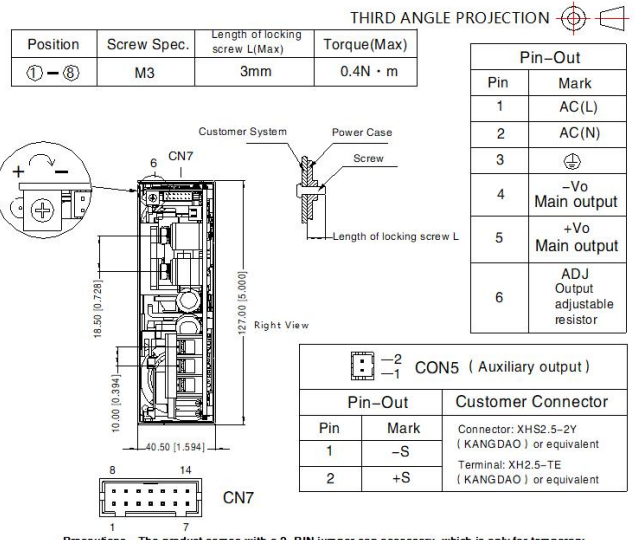
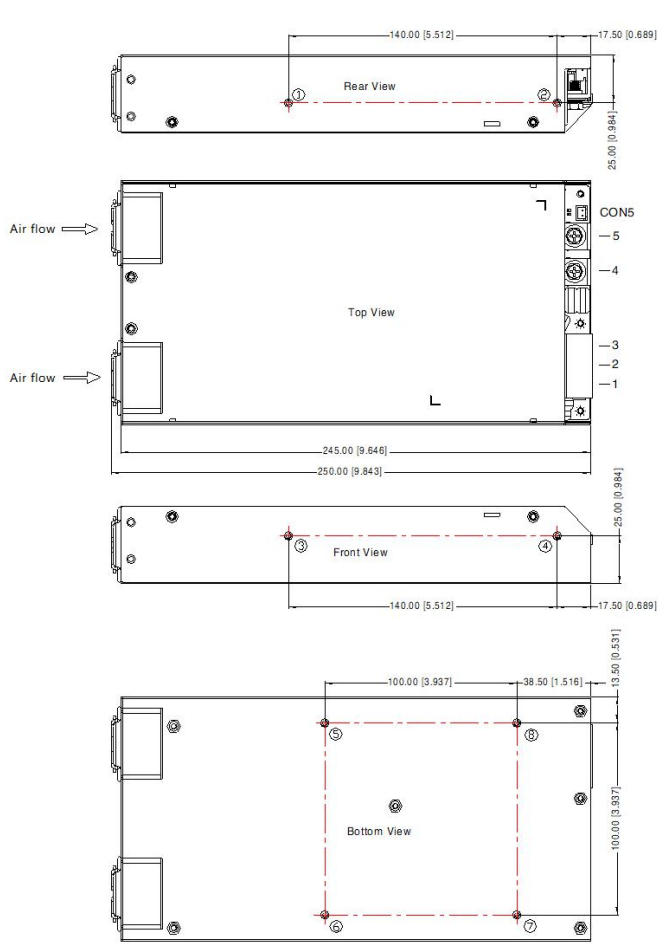

- Note:
1. Pin 12,13 of CN7 are reserved and have no actual function.
 2. The bottom mounting hole of LMF1500 series products is based on the output side, which is compatible with our LMF1000 series products;
 3. LMF1500 series products can be used with adapter plate: Compatible with the installation mode of mainstream 1500W products in the market. Please consult FAE for EMC test operation instructions.
 4. The PJA-XXX series is the accessories of products, quotation is available.

- Note:
1. For additional information on Product Packaging please refer to www.mornsun-power.com. Packaging bag number: 58220287;
 2. Unless otherwise specified, parameters in this datasheet were measured under the conditions of Ta=25°C, humidity <75%RH with nominal input voltage and rated output load;
 3. The room temperature derating of 5°C/1000m is needed for operating altitude greater than 2000m;
 4. All index testing methods in this datasheet are based on our company corporate standards;
 5. We can provide product customization service, please contact our technicians directly for specific information;
 6. Products are related to laws and regulations: see "Features" and "EMC";
 7. The out case needs to be connected to PE (⊕) of system when the terminal equipment in operating;
 8. Our products shall be classified according to ISO14001 and related environmental laws and regulations, and shall be handled by qualified units;
 9. The power supply is considered a component which will be installed into a terminal equipment. All EMC tests should be confirmed with the final equipment. Please consult our FAE for EMC test operation instructions;
 10. In the appearance dimension drawing, ±Vo represents the main output, ±S represents the auxiliary output, and the auxiliary output can be selected by the customer, which has no effect on the main output.

Mornsun Guangzhou Science & Technology Co., Ltd.

Address: No. 5, Kehui St. 1, Kehui Development Center, Science Ave., Guangzhou Science City, Huangpu District, Guangzhou, P. R. China

LMF1500-20Bxx(-QQ) Power Supply Application Note

Content

1. Overview.....	7
2. Function Manual.....	11
2.1 Input Requirements.....	11
2.2 Output Requirements.....	11
2.3 Start-up timing.....	11
2.4 Fan Speed Control.....	12
2.5 Output over-voltage protection(OVP).....	12
2.6 Output over-current protection(OCP).....	13
2.7 Output short circuit protection(SCP).....	13
2.8 Over temperature protection(OTP).....	14
2.9 Output power derating.....	14
2.10 Remote control.....	14
2.11 DC_OK Signal.....	15
2.12 Remote compensation.....	16
2.13 Parallel operation.....	17
2.13.1 Redundancy.....	17
2.13.2 Current sharing.....	17
2.14 I2C communication address.....	19
3. Installation requirements.....	20
3.1 Safety introduction.....	20
3.2 Safety requirements.....	20
3.3 Installation method.....	20
4. Communication protocol.....	22

1. Overview

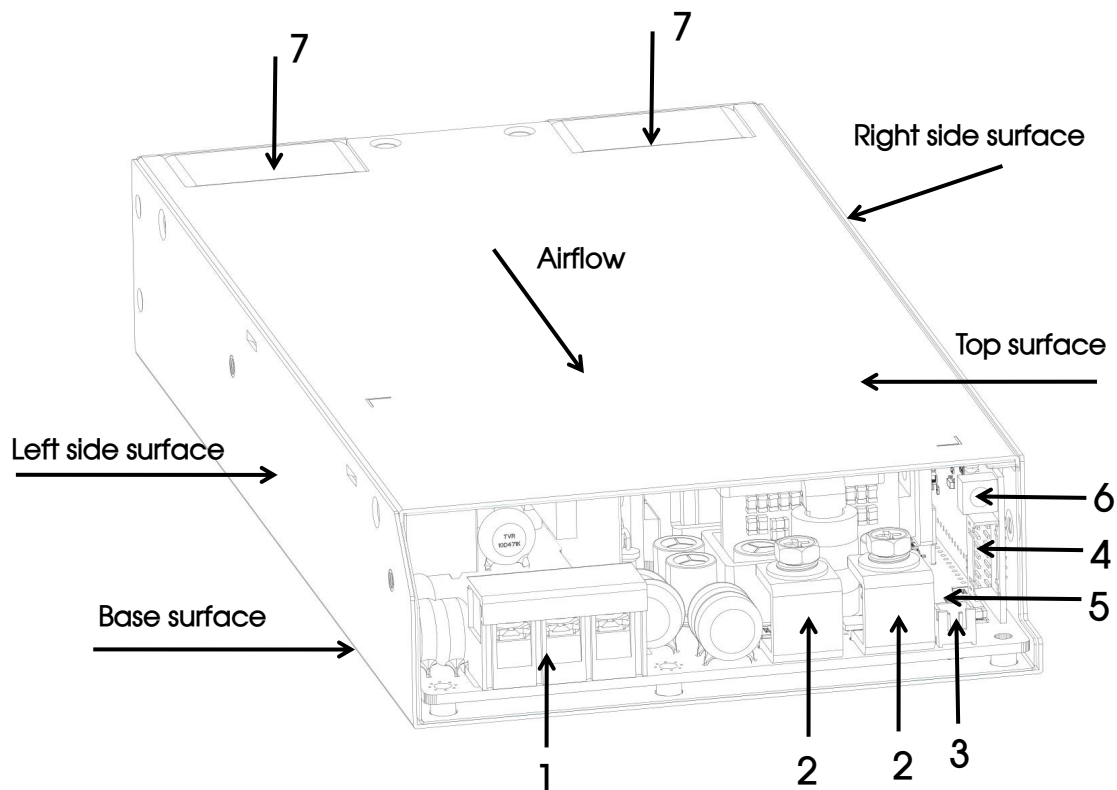

Fig. 1: Appearance information of LMF1500-20Bxx(-QQ)

Overview description:

1. AC/DC input terminal (J1)
2. DC main output terminal (J2, J3)
3. Auxiliary road output terminal (CON5)
4. Signal connection press the terminal (CN7)
5. Green and red status display LED lights
6. Output voltage regulation resistor
7. Fans

1.1 AC/DC input terminal block (J1)

The input terminal J1, as a standard 3-pin fence welding terminal with upper cover, the center spacing of the pins is 10mm.

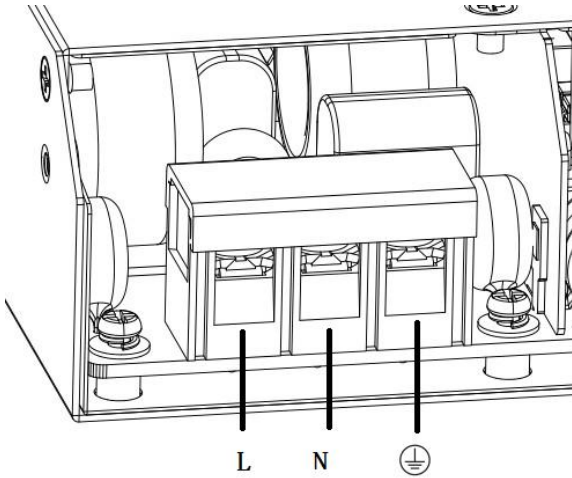

Pin	Features
L	Line (Phase)
N	Neutral
	Ground/Earth

Wire size: 12-22AWG
Torque: 1.2N·m (max)

1.2 Main DC output terminal (J2, J3)

The output terminal uses two standard screw lock type metal terminals, the pin spacing between each is 18mm.

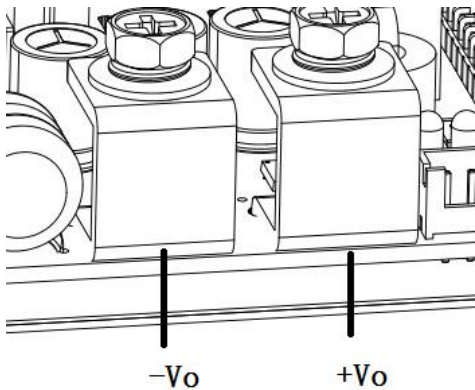

Pin	Features
+Vo	Main output +
-Vo	Main output -

Torque: 2.3N·m

1.3 Auxilliary DC output terminal (CON5)

The auxilliary output terminal with a standard terminal of 2.5mm pitch.

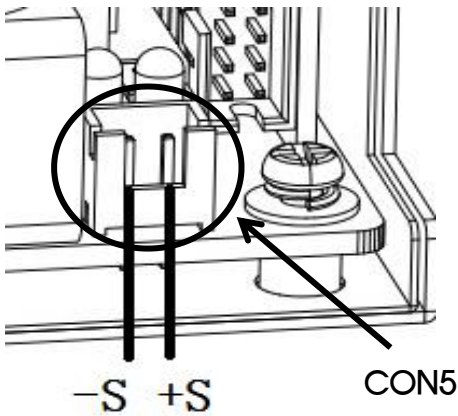

Pin	Function
-S	Auxiliary DC output -
+S	Auxiliary DC output +

1.4 Signal port (CN7)

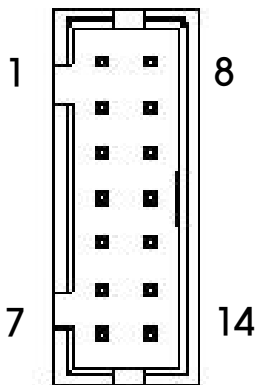

Pin	Label	Features
1	VS+	Remote compensation positive terminal
2	CURRENT SHARE	Current sharing bus
3	DC_OK	DC_OK Signal
4	SCL	I2C communication line
5	SDA	I2C communication line
6	PS_ON	Remote control signal
7	GND	Signal terminal reference ground
8	VS-	Remote compensation negative terminal
9	ADDRESS0	ADDRESS code 0
10	ADDRESS1	ADDRESS code 1
11	ADDRESS2	ADDRESS code 2
12	RXD	Serial communication
13	TXD	Serial communication
14	GND	Signal terminal reference ground

Note: The reference ground of all pins on the signal terminal is pin7 and pin14. Pin 12,13 are reserved and have no actual function.

1.5 Green and red status display LED lights

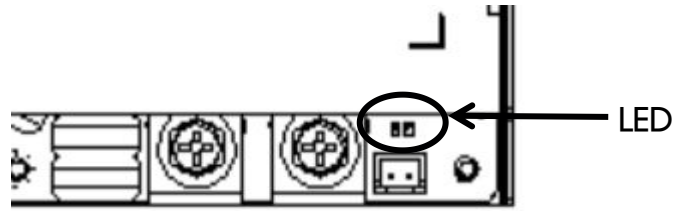

Two kinds of LED lights indicate difference working states of the power supply:

Green LED	Red LED	Status
ON	OFF	Normal work
OFF	ON	Main or auxiliary road alarm
OFF	OFF	No input

1.6 Output voltage adjustment knob

Turn counterclockwise to increase output voltage

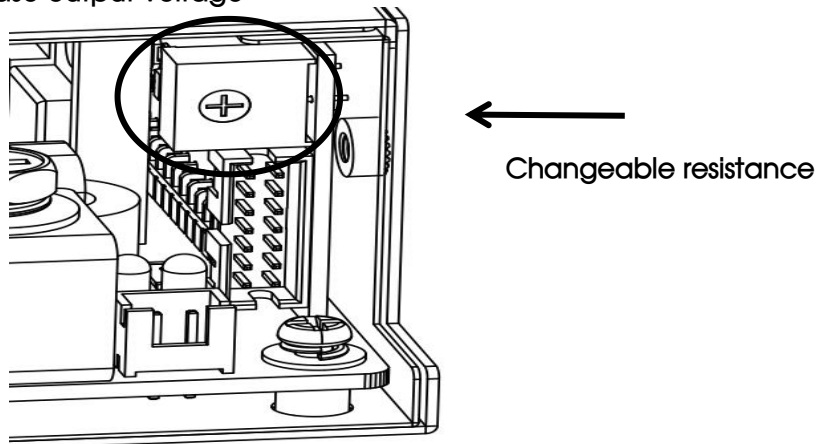

Model	Rated Output Voltage	Adjustable Range Of Output Voltage
LMF1500-20B12	12V	12 - 14.4V
LMF1500-20B15	15V	15 - 18.0V
LMF1500-20B24	24V	24 - 28.8V
LMF1500-20B27	27V	27 - 32.4V
LMF1500-20B36	36V	36 - 43.2V
LMF1500-20B48	48V	48 - 56.0V
LMF1500-20B54	54V	54 - 58.0V

2. Function Manual

2.1 Input requirements

The AC input voltage and DC input voltage must be within the defined voltage range (refer to data-sheet), otherwise the power supply may not work properly or even malfunction. The internal L and N line of the power module have been connected in series with a 250V 25A fuse. For better protection, it is recommended that customers use a circuit breaker not greater than 25A (Non-mandatory requirement).

2.2 Output requirements

Main output

At any voltage value, the maximum output current and power must not exceed the rated/specified value. The output current must not exceed the maximum output current value.

Auxiliary output

The auxiliary circuit supports a maximum current of 2A.

2.3 Start-up timing

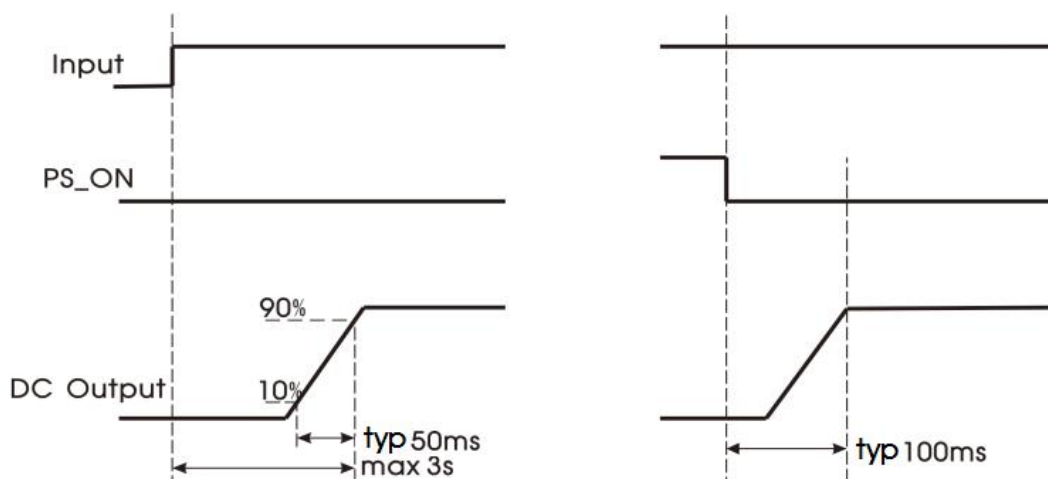

Item	Operating Conditions		Min.	Typ.	Max.	Unit
Power-off Hold Time	Room temperature, full load	115VAC	12	--	--	ms
		230VAC	12	--	--	
Start Delay Time	230VAC, full load, 25°C		--	--	3	s

2.4 Fan speed control

Fan speed is determined by output power and output voltage at the same time, refer to the following curve for fan speed change.

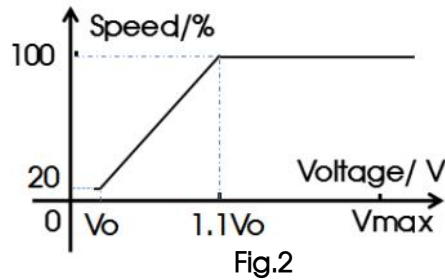
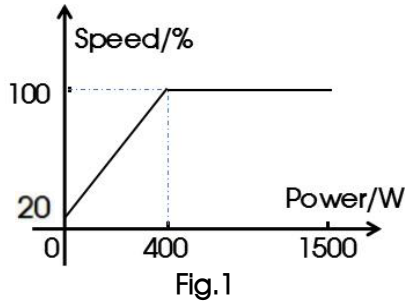

V_o : Rated output voltage

2.5 Output over-voltage protection (OVP)

Main output

The over-voltage protection function is to close the main output when the output voltage reaches the protection voltage value. When the main circuit over-voltage protection occurs, the main circuit output voltage of the module will be shut off, and the auxiliary circuit output will not be affected. The main circuit output can be restored after disconnecting the input power for at least 3 seconds.

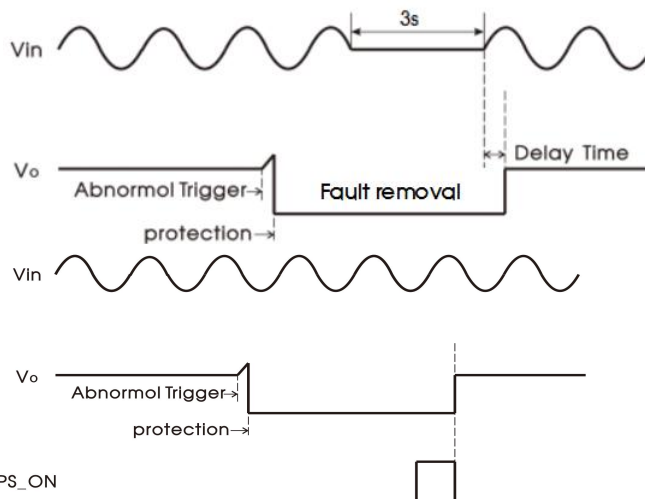

In addition, it can be quickly

Auxiliary output

When the auxiliary circuit voltage reaches 6.3VDC (maximum value), the auxiliary output will be in

hiccup status, and the main output voltage turn off until the auxiliary output returns to normal after the fault is eliminated.

2.6 Output constant-current protection (OCP)

① Main circuit overcurrent

If in CC load mode, when the current exceeds the constant current point, the output enters hiccup mode; when the over current state is released, the output returns to normal.

If in CR/CV load mode, the relationship among output current, voltage and resistance is shown in the following curve:

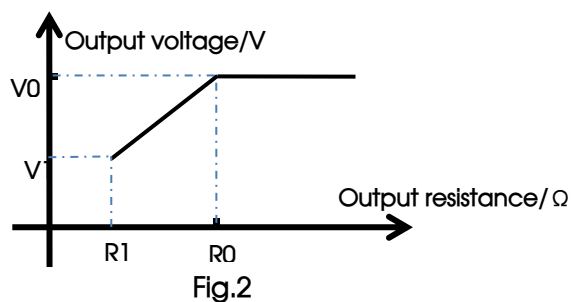
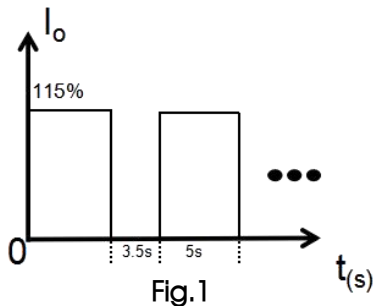

When the product enters the constant current state, the output state circulates as shown in Fig.1, working for 5s and protecting for 3.5s, until the constant current state is released.

In that above Fig.2 the slope corresponding to section R1-R2 is the output current corresponding to constant current. Generally, $V_1 \cong 75\%V_0$.

② Auxiliary circuit overcurrent

When the auxiliary output current exceeds 120% (typ.) of the rated current, turn off the main output. After the overflows state is removed, the main route automatically recovers output after restart.

2.7 Output short circuit protection (SCP)

When the output is short-circuited, the power output in hiccup with interval 3.5s. After the short-circuit is removed, the power module will automatically return to normal, and the auxiliary output will not be affected.

When the auxiliary circuit output is short-circuited, the main circuit without output.

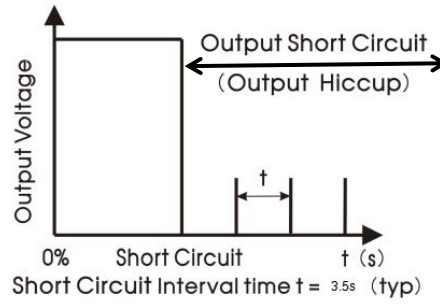

2.8 Over-temperature protection (OTP)

When the ambient temperature of the power supply exceeds the rated temperature for a period of time, the power supply will be turned off and the power supply will resume normal operation after the ambient temperature drops to the set value.

2.9 Output power derating

When the input voltage is greater than 100VAC (or 200VDC), only need to derate according to the temperature derating curve.

When the input voltage is lower than 100VAC (or 200VDC), the output power will be derated according to the following input voltage derating curve after temperature derating.

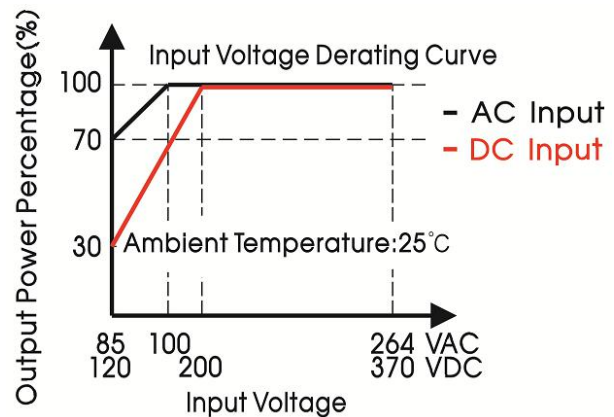
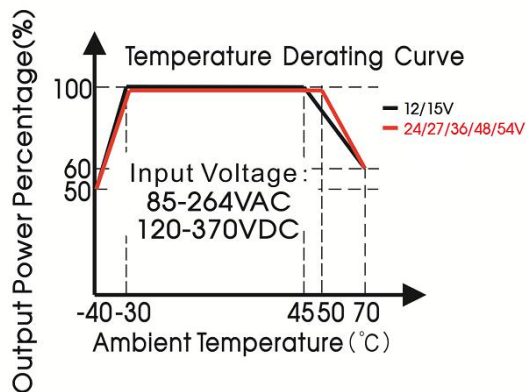

2.10 Remote control

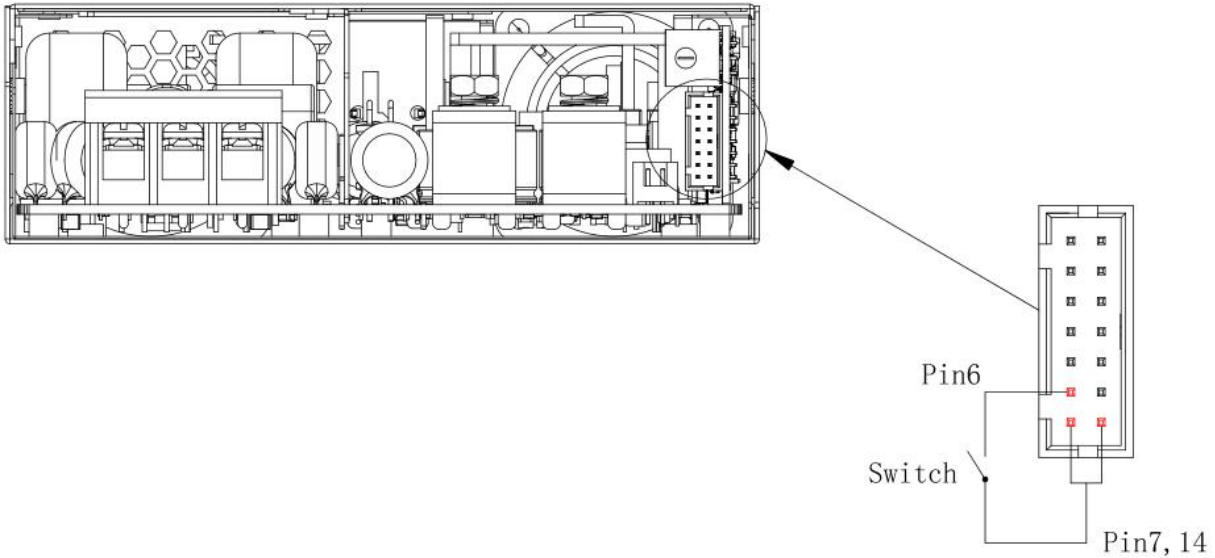

PS_ON (Pin6) and GND (Pin7or Pin14)	Output Status
Short-Circuit	Output on
Pin floating	Output off

If the input terminal of the power module has been connected to a power source, the PS_ON signal pin can be used to control the on and off of the main output, and the PS_ON signal does not affect the output voltage of the auxiliary circuit.

Note: The internal PS_ON input impedance of the module is 5.1K.

2.11 DC_OK signal

The DC_OK signal is used to monitor whether the power supply is working normally, and the signal is at Pin3 of the signal terminal CN7.

Note: When the DC_OK signal is connected to the external circuit, the impedance of the external external circuit (i.e. between Pin3 and Pin7 or Pin14 of CN7) is not less than 10kΩ.

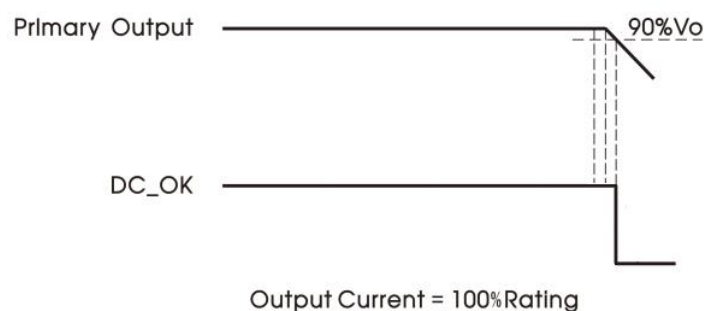

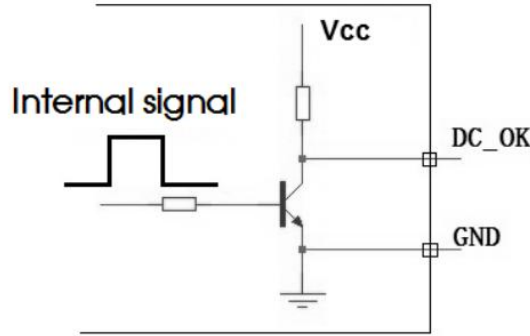

DC_OK (Pin3) and GND (Pin7 or Pin14)	Output State
2.5 - 5V	Output on
0 - 0.5V	Output off

2.12 Remote compensation

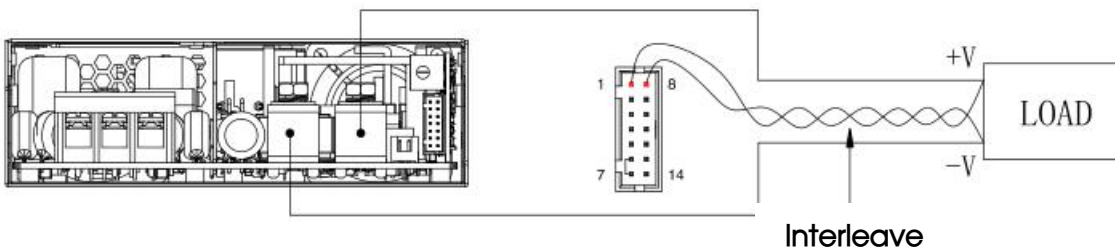

Note:

1. V_{s+} and V_{s-} cannot be shorted or reversed, otherwise the power module will be damaged.
2. Before powering on the product, please confirm whether the control signal connection terminal (CN7) Pin6 (PS_ON) and Pin7 (GND) short-circuit jumper cap are connected. If not, the product without output. When the control signal connection terminal (CN7) of the product are external connected as a whole, please ensure that Pin6 and Pin7 (or Pin14) are short-circuit connected. MORNSUN has PJA-047 jumper terminals for sale. Please refer to LMF1500-20B xx(-QQ) Series Power Supply Application Notes: 2.10 Remote control.
3. Pin 1 and pin 8 of the signal terminal CN7 can compensate the voltage drop on the output cable.
4. The remote compensation circuit can compensate up to 200mV cable voltage drop. This voltage includes the sum of the cable drop connected to the output positive terminal and the output negative terminal.
5. If you need to use the remote compensation function, the signal pin needs to be connected with the load end with a twisted pair cable.

2.13 Parallel operation

2.13.1 Redundancy

The power module output can be connected in parallel to achieve redundancy, thereby improving system reliability. The maximum power of the redundant system needs to be derated to ensure that the redundant system can still meet the rated load requirements when a power supply module fails. The current common practice is to construct a redundant system by the N+1 method, that is, N+1 power supplies are connected in parallel, to support the maximum load current $N \cdot I_{omax}$, where I_{omax} is the rated output current of each power supply. For example, the rated output current of each power supply is 40A, and 3+1 units are connected in parallel to construct a $3 \cdot 40A = 120A$ redundant system.

The power module supports 3+1 parallel redundant operation.

The ORing circuit is used inside the power module, and when any one of the power modules in the parallel fails, it will not affect the work of other power modules.

When used in parallel, the maximum load current cannot exceed the maximum output current of a single power supply module, otherwise the whole parallel power supply module will not start normally.

2.13.2 Current sharing

Method 1: Current sharing bus and remote compensation lines are both connected.

For load line loss $\leq 200mV$, and the output voltage difference of each single module $\leq 50mV$, this type of connection is recommended to obtain a better line-end output voltage and current sharing effect.

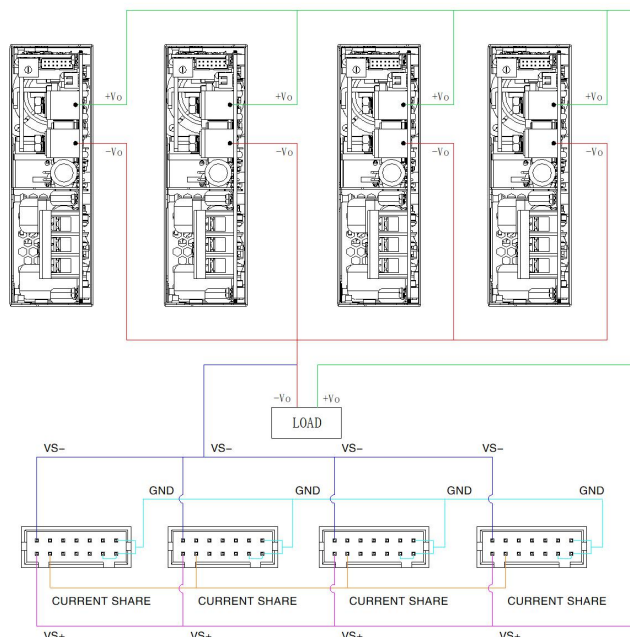

Method 2: Only the current sharing bus is connected, and the remote compensation is not connected.

For the load line loss $\geq 200\text{mV}$, or the output voltage difference of each single module cannot or does not need to be accurately adjusted to $\leq 50\text{mV}$, this type of connection is recommended to obtain a better current sharing effect of the parallel machine. In the same way, when the load loss is unknown or the current sharing fails to meet the specifications under the first connection method, it is recommended to replace it with this connected method. The wiring method of the current sharing function is shown in the figure below:

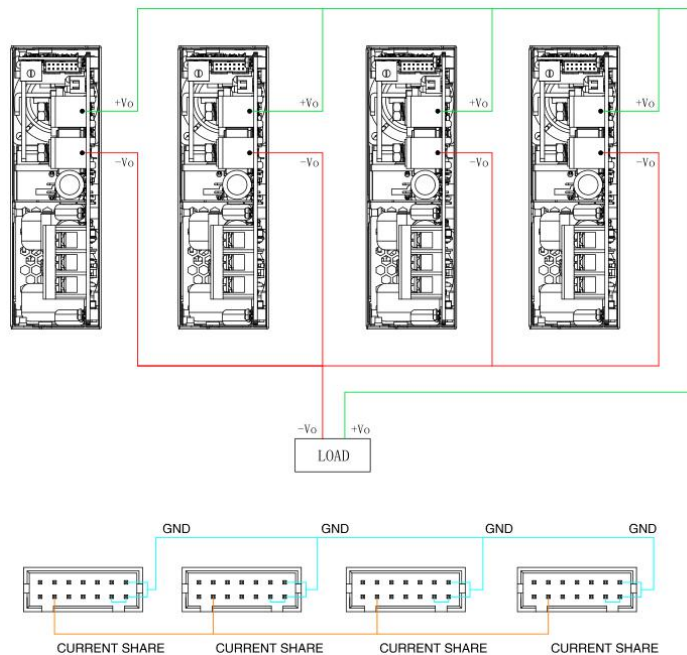

Note: 1. When using in parallel, the number of parallel modules cannot exceed 4.

2. Before powering on the product, please confirm whether the control signal connection terminal (CN7) Pin6 (PS_ON) and Pin7 (GND) short-circuit jumper cap are connected. If not, the product without output. When the control signal connection terminal (CN7) of the product are external connected as a whole, please ensure that Pin6 and Pin7 (or Pin14) are short-circuit connected. MORNSUN has PJA-047 jumper terminals for sale. Please refer to LMF1500-20Bxx(-QQ) Series Power Supply Application Notes: 2.10 Remote control.

When power modules work in parallel, there is an internal active current sharing circuit to ensure that the current between each module is balanced.

The active current sharing circuit adopts the automatic master-slave current sharing method. Each power module has a current sharing bus signal (CURRENT SHARE BUS). When working in parallel, the current sharing bus of all power modules must be connected together. The current-sharing bus signal is

located at pin 2 of CN7.

The output voltage of each power module will affect the current sharing accuracy. The output voltage of the power module is the rated voltage $\pm 50\text{mV}$. In practical applications, if the output voltage value needs to be adjusted, the output voltage of all parallel power supply modules needs to be adjusted to the same voltage. The recommended voltage range: target voltage value $\pm 50\text{mV}$

After the output load of each power module is greater than 50% of the rated load, the current sharing accuracy should be $\pm 5\%$. The current sharing calculation formula is:

$$\text{Current sharing accuracy} = \frac{I_{o \max} - I_{o \min}}{I_{o \max}} * 100\%$$

$I_{o \max}$: the maximum output current value in parallel power supply modules.

$I_{o \min}$: the minimum output current value in parallel power supply modules.

2.14 I2C communication address

In the parallel system, if you need to identify the power module information, you need to set the I2C communication address for each parallel power module, and exchange data with the host computer through I2C. The setting of the communication address is determined by pins 9, 10 and 11 of the signal terminal CN7. When these three pins are short-circuited with pin 7 or 14 of CN7, it will be low level (L, voltage range: 0 - 1.31V). When disconnected, it is high level (H, voltage range: 1.99V - 3.3V), one bus can match up to 7 prototypes for communication. The specific address number is shown in the table below:

ADDRESS 2	ADDRESS 1	ADDRESS 0	Address number
L	L	L	0
L	L	H	1
L	H	L	2
L	H	H	3
H	L	L	4
H	L	H	5
H	H	L	6
H	H	H	7

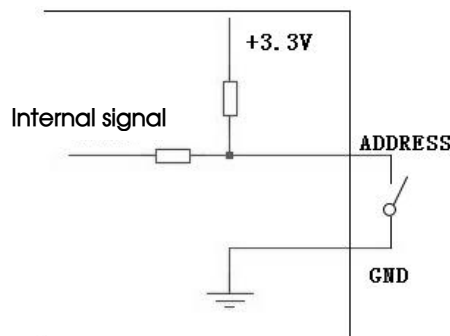

The internal pull-up resistance value of the power module is $10\text{k}\Omega$, and the external impedance can

be matched according to the actual application to meet the high and low voltage range.

3. Installation requirements

3.1 Safety introduction

Warning: Risk of electric shock

During high voltage operating

- The power supply module is disconnected from the input DC or the AC power and placed for at least one minute before starting to operate it.
- When installing the input wire to the power module, please connect the ground terminal first, and then connect the L line and the N line.
- When removing the input wire, please remove the L wire and the N wire first, and then remove the ground wire.
- When disassembling, make sure that no objects fall into the power module.
- Pay attention to high temperature.
- After the power module is working in a high temperature environment, wait for its shell to cool down before operating.
- This product needs to be installed by professionals and needs to be used with other equipment.

3.2 Safety requirements

When installing, pay attention to the primary side and the protective ground, the creep distance and the electrical clearance of the primary side and the secondary side refer to EN60601-1.

3.3 Installation method

Standard mounting orientation:

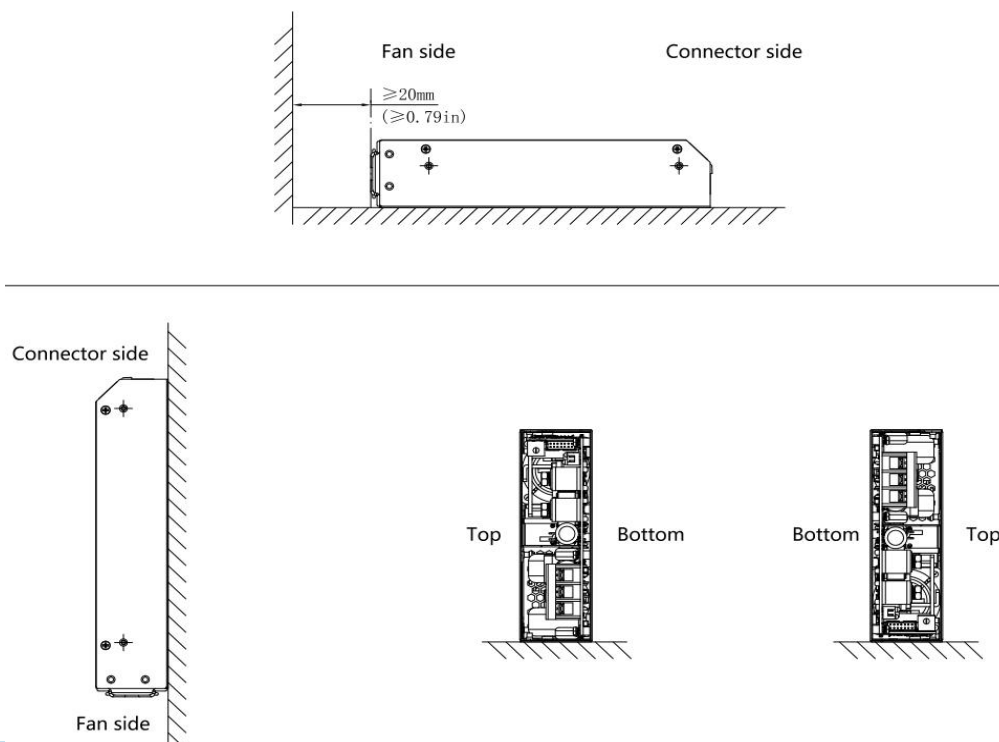

Position of mounting holes:

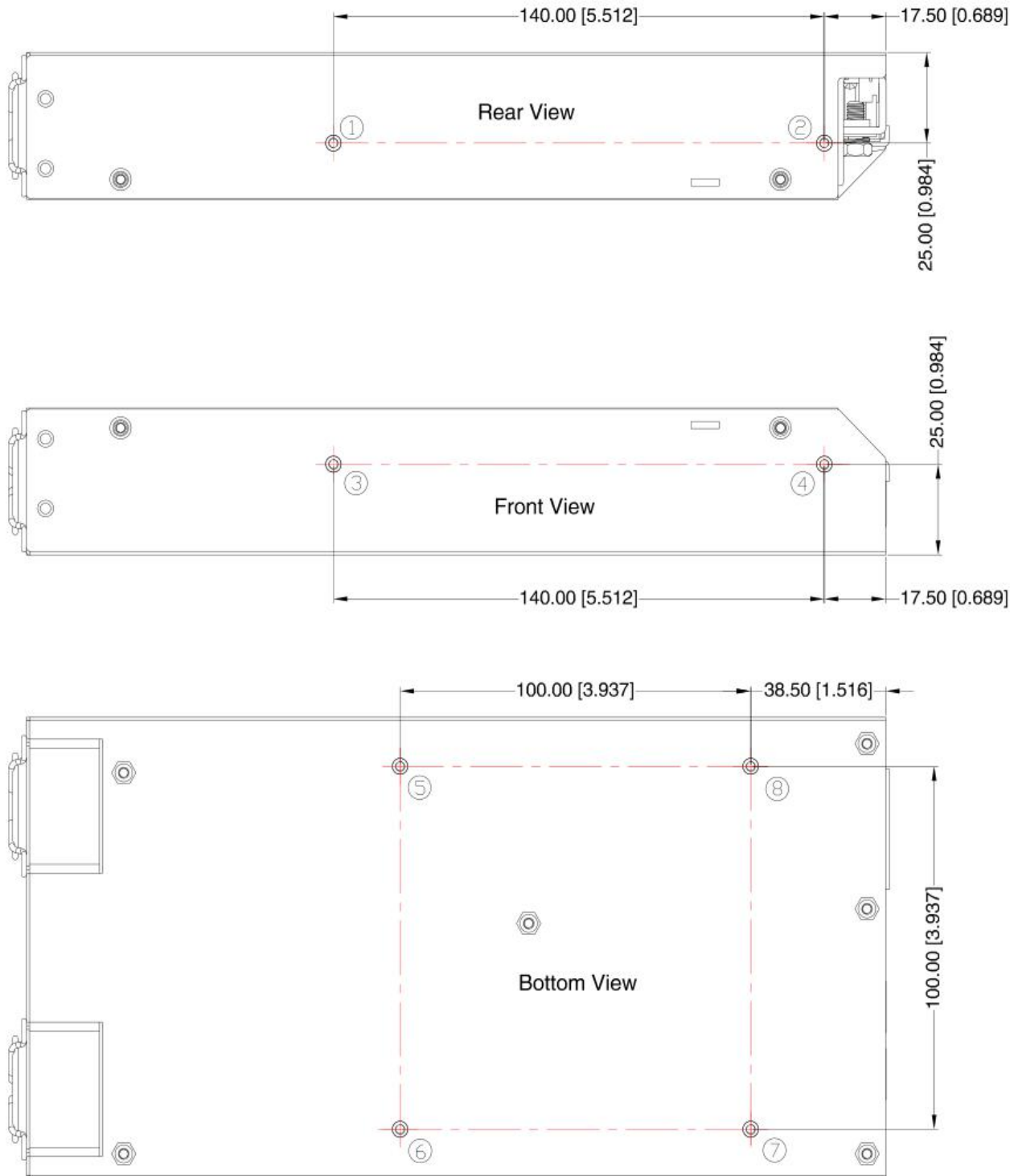

Note: The fan panel cannot be blocked by other objects, and a distance of at least 20mm must be maintained, otherwise it will affect the heat dissipation and performance of the power module.

4. Communication protocol

The LMF1500-20Bxx(-QQ) series power modules support standard communication protocols and manage and monitor the power modules through I2C bus.

Command Code	Command Name	Access Type	Data Bytes	Data Format	Description
0x9A	PMB_MFR_MODEL	Block Read	32	ASCII	Product model
0x8B	PMB_READ_VOUT	Read Word	2	Direct	Main circuit output voltage (10mV)
0x8C	PMB_READ_IOUT	Read Word	2	Direct	Main output current (10mV)
0x96	PMB_READ_POUT	Read Word	2	Direct	Main output power (10mV)
0xC4	PMB_MFR_AUX_VOUT	Read Word	2	Direct	Auxiliary output Voltage (10mV)
0xC5	PMB_MFR_AUX_IOUT	Read Word	2	Direct	Auxiliary output current (10mV)
0xC7	PMB_MFR_FAULT_BIT	Read Word	2	Bit Field	Fault status word

Describe Of Fault Status Through PMB_MFR_FAULT_BIT	
Bit Segment	Description
BIT: 0	0: Fan 1 normal 1: Fan 1 fault
BIT: 1	0: Fan 2 normal 1: Fan 2 fault
BIT: 2	0: Auxillary output normal 1: Auxillary output abnormal
BIT: 3	0: No over-voltage in main circuit 1: Over-voltage in main circuit
BIT: 4	0: No under-voltage in main circuit 1: Under-voltage in main circuit
BIT: 5	0: No level 1 over-current in main circuit 1: Level 1 over-current in main circuit
BIT: 6	0: No level 2 over-current in main circuit 1: level 2 over-current in main circuit
BIT: 7	0: No level 1 over-load in main circuit 1: Level 1 over-load in main circuit
BIT: 8	0: No level 2 over-load in main circuit 1: Level 2 over-load in main circuit
BIT: 9	0: No level 3 over-load in main circuit 1: Level 3 over-load in main circuit
BIT: 10	0: Normal temperature 1: Over-temperature and over-load
BIT: 11	0: No short circuit in main circuit 1: Short circuit in main circuit
BIT: 12	0: No hardware over-voltage in main circuit 1: Main circuit hardware over-voltage fault
BIT: 13	0: No hardware under-voltage in main circuit 1: Main circuit hardware under-voltage fault
BIT: 14	0: Pre-charge normal 1: Pre-charge fault
BIT: 15	0: PFC soft start normal 1: PFC soft start fault

For more details, please consult the MORNSUN FAE.